

| Tank | |
|---------------------|-------------------|
| Content | Diesel |
| External size (LWH) | 12192x2438x2896mm |
| Internal size (LWH) | 11106x2374x2690mm |
| Total volume | 69023L |
| Safe volume (95%) | 65570L |

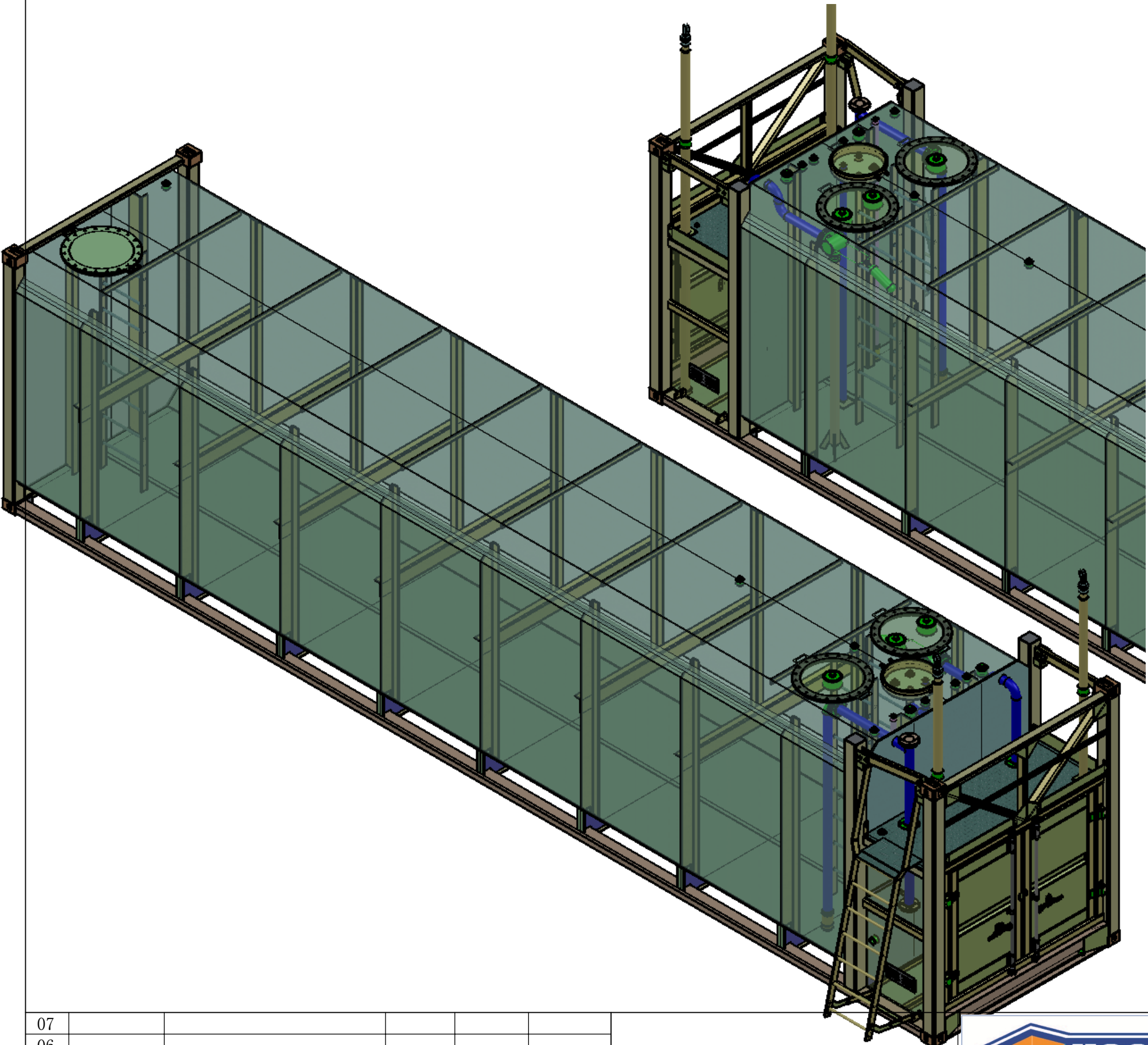

| | | | | | |
|------|-------|-----------|--------|----------|-----------|
| 07 | | | | | |
| 06 | | | | | |
| 05 | | | | | |
| 04 | | | | | |
| 03 | | | | | |
| 02 | | | | | |
| 01 | | | | | |
| REV: | DATE: | REVISION: | DRAWN: | CHECKED: | APPROVED: |

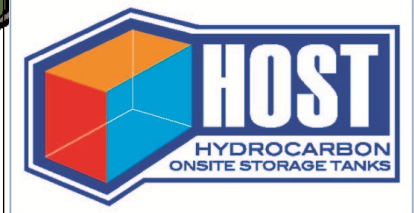

Material: _____
 Weight: 13447.67KG

| | | | |
|-----------|--------------|----------------------|-----------------|
| DRAWN: | SAVING DATE: | TITLE: | |
| | 2016/3/15 | 40' HC | |
| CHECKED: | DATE: | DRAWING NO. : | REV: |
| CLIENT: | DATE: | | SHEET: |
| | | | 1 of 21 |
| APPROVED: | DATE: | PURCHASE ORDER NO. : | Scale: No scale |
| | | | ⊕ - ▷ |

A3

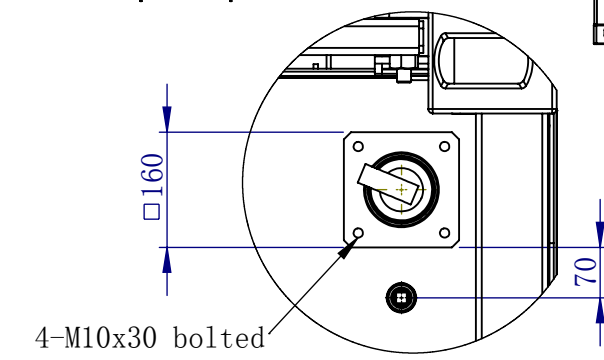
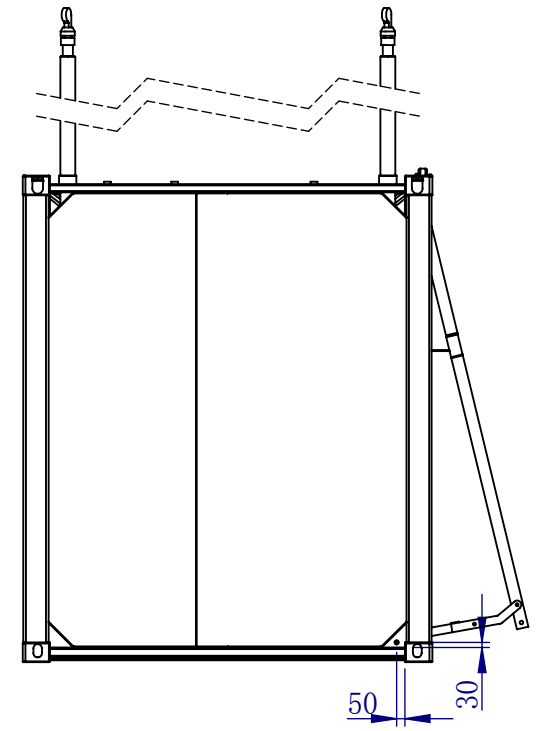
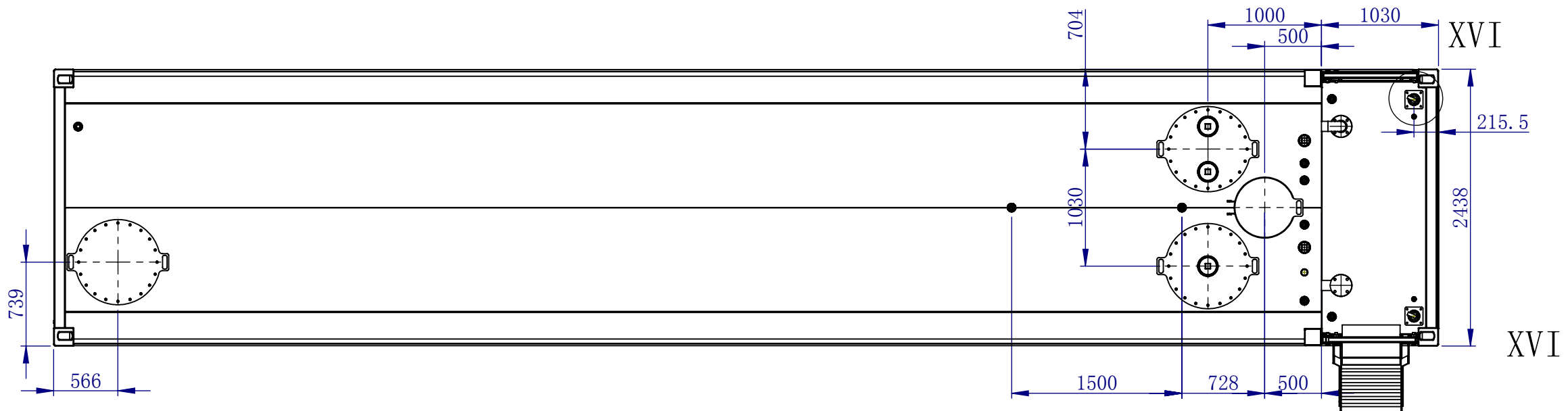
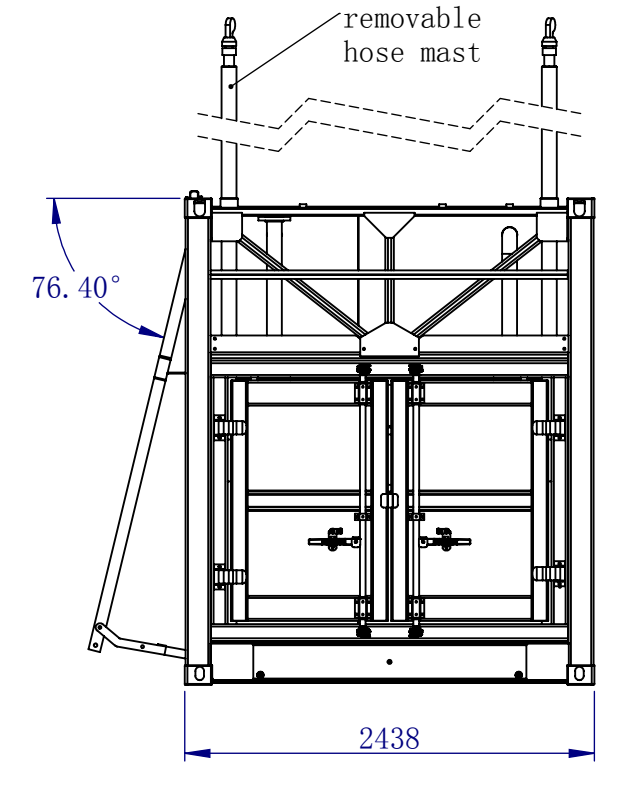
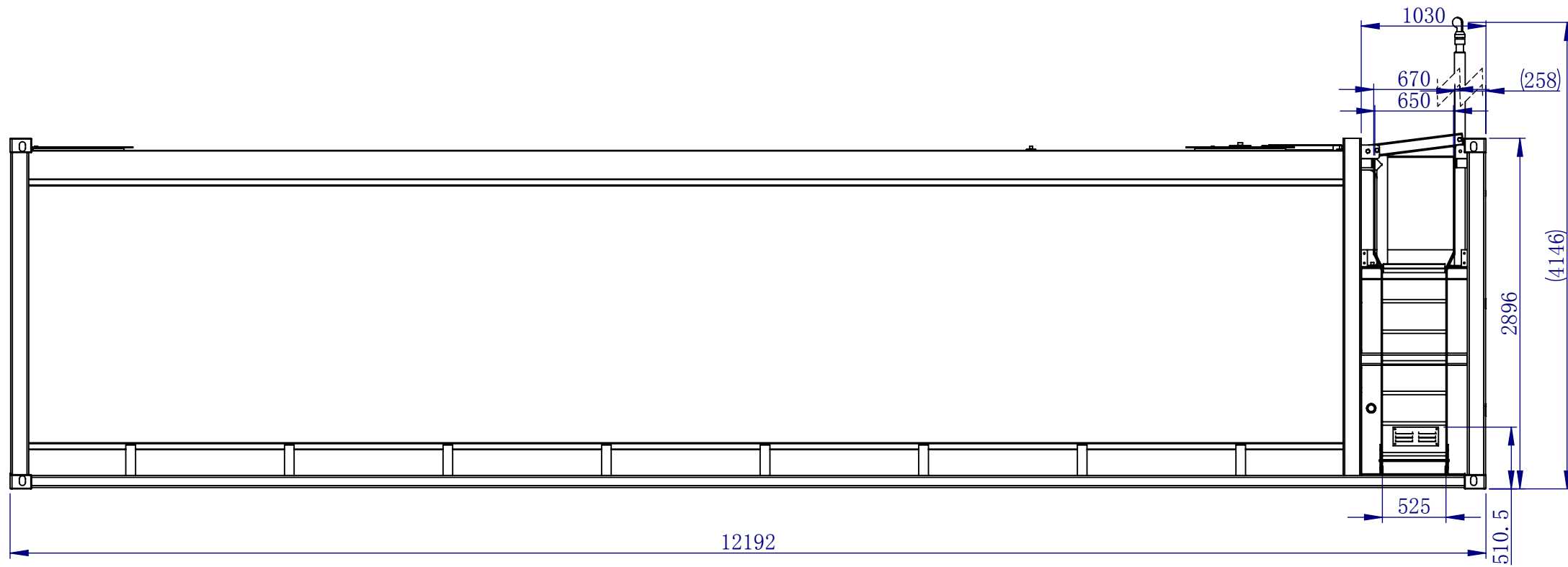

| | | | | | |
|------|-------|-----------|--------|----------|-----------|
| 07 | | | | | |
| 06 | | | | | |
| 05 | | | | | |
| 04 | | | | | |
| 03 | | | | | |
| 02 | | | | | |
| 01 | | | | | |
| REV: | DATE: | REVISION: | DRAWN: | CHECKED: | APPROVED: |

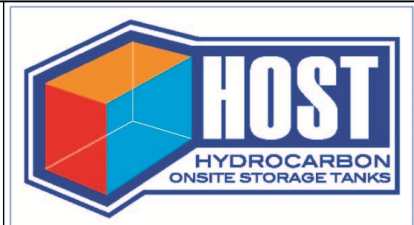

Material:
Weight: 13447.67KG

DRAWN:
CHECKED:
CLIENT:
APPROVED:

SAVING DATE: 2016/3/15
DATE:
DATE:
DATE:
TITLE: 40' HC
DRAWING NO. :
REV:
SHEET: 2 of 21
PURCHASE ORDER NO. :
Scale: No scale

A3

